

**GHIERA STOP NORMALE CON
RONDELLA NYLON - R=450/550 N/mm²**
 SELF LOCKING RING-NUT STANDARD
 NORMAL NUTTMUTTER
 ECROUS A ENCOCHES FREINE' NORMAL

ACCIAIO - UNI CF9SMn Pb28

STEEL - BS 230 M07 Pb
 STAHL - DIN 9SMn Pb 28
 ACIER - AFNOR S 300 Pb

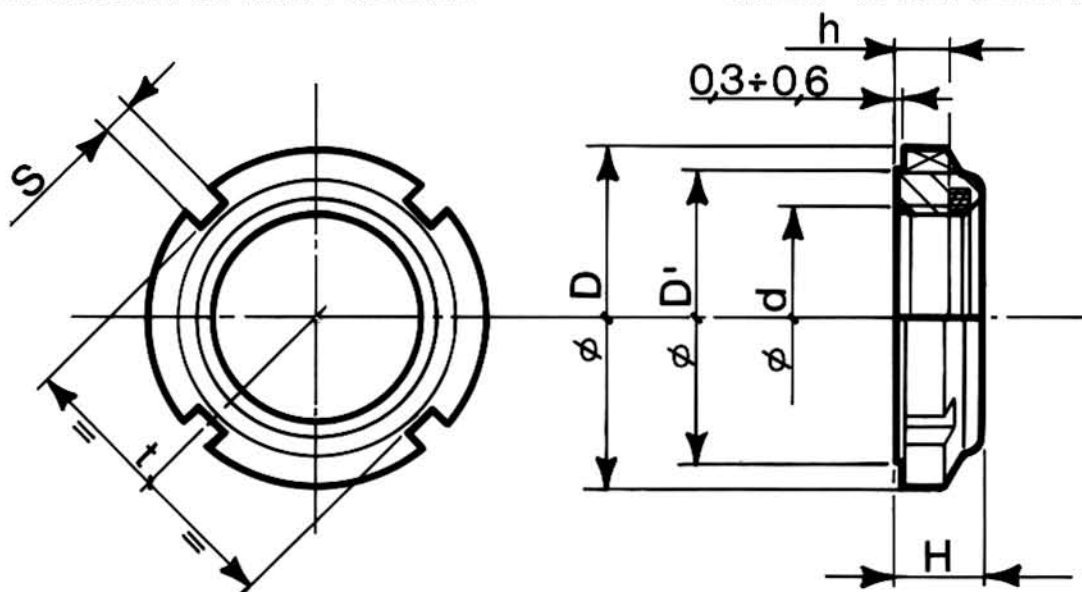

CODICE CODE	FILETTATURA d	D	D'=t	H	h	S	N° cave
G.S. 6S/N/10X0,75	M 10X0,75	18	15	7,4	4,5	3	4
G.S. 6S/N/12X1	M 12X1	21	18	7,4	4,5	3	4
G.S. 6S/N/15X1	M 15X1	24	21	8,4	5,5	4	4
G.S. 6S/N/17X1	M 17X1	28	24	8,4	5,5	4	4
G.S. 6S/N/20X1	M 20X1	32	27	9,4	6,5	4	4
G.S. 6S/N/25X1,5	M 25X1,5	38	33	10,3	6,5	5	4
G.S. 6S/N/30X1,5	M 30X1,5	44	38	10,9	6,5	5	4
G.S. 6S/N/35X1,5	M 35X1,5	50	44	11,1	7	5	4
G.S. 6S/N/40X1,5	M 40X1,5	56	50	12,1	8,2	6	4
G.S. 6S/N/45X1,5	M 45X1,5	62	55	12,1	8,2	6	4
G.S. 6S/N/50X1,5	M 50X1,5	68	61	12,7	8,5	6	4
G.S. 6S/N/55X2	M 55X2	75	68	13,2	8,5	7	6
G.S. 6S/N/60X2	M 60X2	80	73	13,2	8,5	7	6
G.S. 6S/N/65X2	M 65X2	85	77	14,3	9,5	7	6
G.S. 6S/N/70X2	M 70X2	92	84	14,3	9,5	8	6
G.S. 6S/N/75X2	M 75X2	98	89	15,3	10,5	8	6
G.S. 6S/N/80X2	M 80X2	105	96	16,3	11,5	8	8
G.S. 6S/N/85X2	M 85X2	110	100	17,3	12,5	8	8
G.S. 6S/N/90X2	M 90X2	120	110	17,5	12,5	10	8
G.S. 6S/N/95X2	M 95X2	125	115	18,5	13,5	10	8
G.S. 6S/N/100X2	M 100X2	130	120	19,5	14,5	10	8

Trattamento superficiale: zincatura passivata bianca

ARPI S.r.l. - Via T. Tasso, 46 - 42023 CADELBO스코 DI SOPRA (REGGIO EMILIA) - ITALY
 Tel. 0522/917815 - 917850 Fax 0522/917850